



Vehicle History Report™

2015 BMW 3 SERIES 320I

VIN: WBA3B1G56FNT02612
SEDAN 4 DR
2.0L I4 F DOHC 16V
GASOLINE
REAR WHEEL DRIVE



Branded Titles: Rebuilt, Salvage



2 Service history records



2 Previous owners



Personal vehicle



Last owned in California



61,002 Last reported odometer reading

This CARFAX Vehicle History Report is based only on information supplied to CARFAX and available as of 3/23/23 at 10:19:53 AM (CDT). Other information about this vehicle, including problems, may not have been reported to CARFAX. Use this report as one important tool, along with a vehicle inspection and test drive, to make a better decision about your next used car.



Ownership History

The number of owners is estimated

	Owner 1	Owner 2
Year purchased	2015	2017
Type of owner	Personal	Personal
Estimated length of ownership	2 years	5 yrs. 9 mo.
Owned in the following states/provinces	California	California
Estimated miles driven per year	14,720/yr	---
Last reported odometer reading	29,804	61,002



Title History

CARFAX guarantees the information in this section

	Owner 1	Owner 2
Damage Brands Salvage Junk Rebuilt Fire Flood Hail Lemon	Alert! Problem Found	Alert! Problem Found
Odometer Brands Not Actual Mileage Exceeds Mechanical Limits	No Problem	No Problem



ALERT! - Severe problems were reported by a state Department of Motor Vehicles (DMV). This vehicle does not qualify for the CARFAX Buyback Guarantee.

 Additional History Not all accidents / issues are reported to CARFAX	Owner 1	Owner 2
Total Loss Total Loss Reported: 04/01/2017 and 03/06/2023.	Total Loss Reported	Total Loss Reported
Structural Damage CARFAX recommends that you have this vehicle inspected by a collision repair specialist.	<input checked="" type="checkbox"/> No Issues Reported	<input checked="" type="checkbox"/> No Issues Reported
Airbag Deployment No airbag deployment reported to CARFAX.	<input checked="" type="checkbox"/> No Issues Reported	<input checked="" type="checkbox"/> No Issues Reported
Odometer Check No indication of an odometer rollback.	<input checked="" type="checkbox"/> No Issues Indicated	<input checked="" type="checkbox"/> No Issues Indicated
Accident / Damage DMV title problems reported. Damage reported: 06/29/2015 and 01/28/2016. Accident reported: 03/06/2023. Water damage reported: 04/01/2017.	Severe Damage	Severe Damage
Manufacturer Recall No open recalls reported to CARFAX. Check with an authorized BMW dealer for any open recalls.	<input checked="" type="checkbox"/> No Recalls Reported	<input checked="" type="checkbox"/> No Recalls Reported
Basic Warranty Original manufacturer warranty likely voided by manufacturer.	Warranty Voided	Warranty Voided



Detailed History

	Owner 1 Purchased: 2015	Personal Vehicle 14,720 mi/yr	
Date	Mileage	Source	Comments
03/03/2015	57	California Motor Vehicle Dept. Temecula, CA	Odometer reading reported
03/16/2015		California Motor Vehicle Dept. Temecula, CA	Title issued or updated - First owner reported - Titled or registered as personal vehicle - Loan or lien reported
06/29/2015		Damage Report	 Damage reported: minor damage - Damage to rear

This incident was first available for display by CARFAX on 04/04/2018.

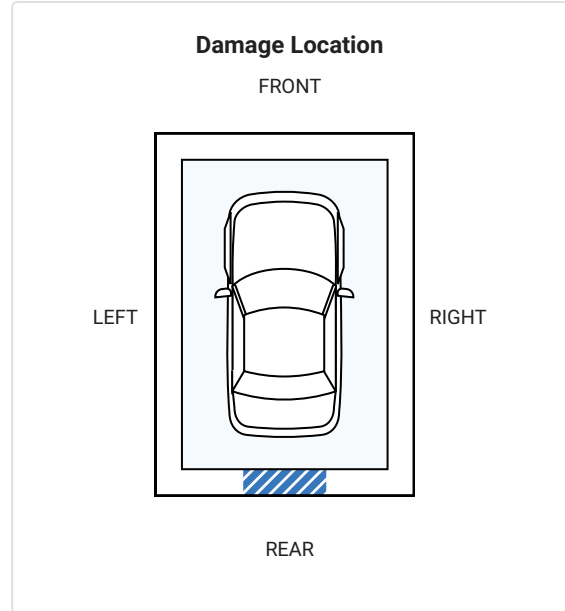
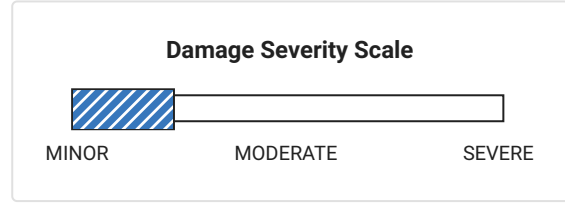

01/28/2016





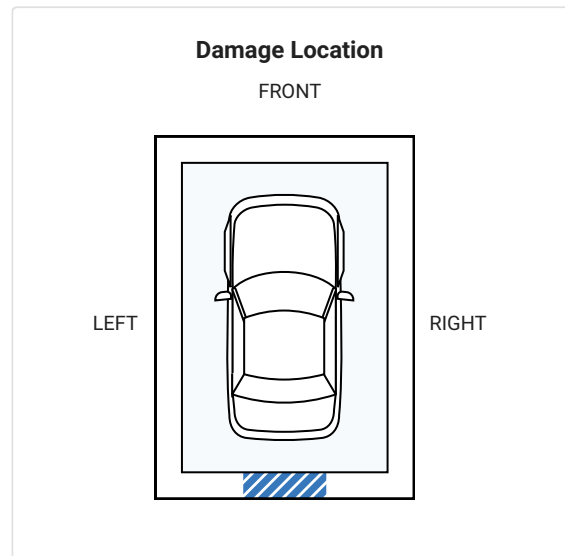
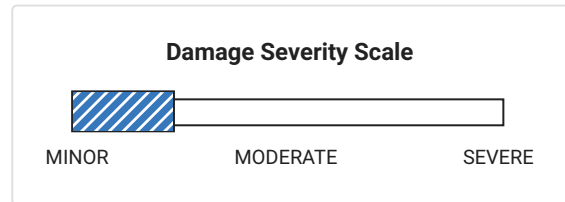

Damage Report

i **Damage reported: minor damage**
- Damage to rear

This incident was first available for display by CARFAX on 04/04/2018.







REAR

Not Reported	Damage Report	 Accident reported
		<div style="border: 1px solid #007bff; padding: 5px;"> <p>Police accident reports are required in California when the estimated damage exceeds \$750. The date of this particular accident was not reported to CARFAX, but it likely occurred between December 2014 and February 2016.</p> </div>
10/19/2016	26,174	
	<p>BMW of San Diego San Diego, CA 858-560-5050</p> <p>★ 4.5 / 5.0 803 Verified Reviews ♥ 20,569 Customer Favorites</p>	 Vehicle serviced <ul style="list-style-type: none"> - Maintenance inspection completed - Tire condition and pressure checked - Engine checked - Vehicle washed/detailed - Engine/powertrain computer/module checked
02/06/2017	29,803	 Vehicle serviced <ul style="list-style-type: none"> - Maintenance inspection completed - Vehicle washed/detailed - Tire condition and pressure checked - Engine electrical system checked
	<p>BMW of San Diego San Diego, CA 858-560-5050</p> <p>★ 4.5 / 5.0 803 Verified Reviews ♥ 20,569 Customer Favorites</p>	
03/08/2017		<p>California Motor Vehicle Dept. Temecula, CA</p> <p>Title issued or updated</p> <ul style="list-style-type: none"> - Loan or lien reported
03/24/2017	29,804	<p>California Motor Vehicle Dept. Vallejo, CA</p> <p>Odometer reading reported</p>
04/01/2017	Damage Report	 TOTAL LOSS VEHICLE <ul style="list-style-type: none"> - Water damage reported
		<div style="border: 1px solid #007bff; padding: 5px;"> <p>There are many reasons an insurance company will declare a vehicle a total loss. Have this vehicle inspected by a qualified technician before you buy. Learn More</p> </div>
04/01/2017		
	<p>California Motor Vehicle Dept.</p> <p>Title or registration issued to insurance company</p>	
04/01/2017		 SALVAGE TITLE/CERTIFICATE ISSUED
	<p>California Motor Vehicle Dept. Vallejo, CA</p>	

 **Owner 2**
Purchased: 2017

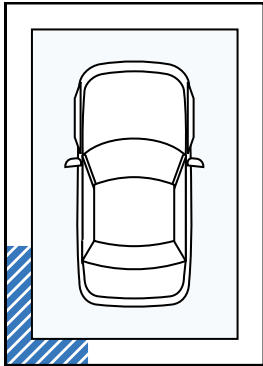
Personal Vehicle

Date	Mileage	Source	Comments
06/03/2017	29,905	California Motor Vehicle Dept. Glendale, CA	Odometer reading reported
07/01/2017	61,002	California Motor Vehicle Dept. Glendale, CA	 New owner reported - REBUILT TITLE ISSUED
03/06/2023		Damage Report	 TOTAL LOSS VEHICLE - Accident reported - Damage to left rear
			<div style="text-align: center;"> <p>Damage Location</p> <p>FRONT</p>  <p>LEFT RIGHT</p> <p>REAR</p> </div>
03/06/2023		California Motor Vehicle Dept.	Title or registration issued to insurance company
03/06/2023		California Motor Vehicle Dept. Rancho Cordova, CA	 Dealer took title of this vehicle while it was in inventory - SALVAGE TITLE/CERTIFICATE ISSUED - REBUILT TITLE ISSUED

Have Questions? Please visit our Help Center at www.carfax.com.



Glossary

Accident Indicator

CARFAX receives information about accidents in all 50 states, the District of Columbia and Canada.

Not every accident is reported to CARFAX. As details about the accident become available, those additional details are added to the CARFAX Vehicle History Report. CARFAX recommends that you have this vehicle inspected by a qualified mechanic.

- According to the National Safety Council, Injury Facts, 2021 edition, 5% of the 276 million registered vehicles in the U.S. were involved in an accident in 2019. Over 77% of these were considered minor or

moderate.

- This CARFAX Vehicle History Report is based only on information supplied to CARFAX and available as of 3/23/23 at 10:19:53 AM (CDT). Other information about this vehicle, including problems, may not have been reported to CARFAX. Use this report as one important tool, along with a vehicle inspection and test drive, to make a better decision about your next used car.

Damage Indicator

Damage can be a result of many different types of events. Examples include contact with objects (other cars, trees, traffic signs, road debris, etc), vandalism, or weather-related events. Not every damage event is reported to CARFAX. As details about the damage event become available, those additional details are added to the CARFAX Vehicle History Report. CARFAX recommends that you have this vehicle inspected by a qualified mechanic.

- This CARFAX Vehicle History Report is based only on information supplied to CARFAX and available as of 3/23/23 at 10:19:53 AM (CDT). Other information about this vehicle, including problems, may not have been reported to CARFAX. Use this report as one important tool, along with a vehicle inspection and test drive, to make a better decision about your next used car.

Damage Severity

Damage events result in one of the following severity levels:

- Minor: Generally, minor damage is cosmetic (including dents or scratches), may only require reconditioning, and typically does not compromise a vehicle's operation and/or safety.
- Moderate: Moderate damage may affect multiple components of the vehicle and may impair the vehicle's operation and/or safety.
- Severe: Severe damage usually affects multiple components of the vehicle and is likely to compromise the vehicle's operation and/or safety.

CARFAX recommends getting a pre-purchase inspection at a certified collision repair facility.

First Owner

When the first owner(s) obtains a title from a Department of Motor Vehicles as proof of ownership.

New Owner Reported

When a vehicle is sold to a new owner, the Title must be transferred to the new owner(s) at a Department of Motor Vehicles.

Ownership History

CARFAX defines an owner as an individual or business that possesses and uses a vehicle. Not all title transactions represent changes in ownership. To provide estimated number of owners, CARFAX proprietary technology analyzes all the events in a vehicle history. Estimated ownership is available for vehicles manufactured after 1991 and titled solely in the US including Puerto Rico. Dealers sometimes opt to take ownership of a vehicle and are required to in the following states: Maine, Massachusetts, New Jersey, Ohio, Oklahoma, Pennsylvania and South Dakota. Please consider this as you review a vehicle's estimated ownership history.

Rebuilt/Reconstructed Title

A Rebuilt/Reconstructed vehicle is a salvage vehicle that has been repaired and restored to operation. These vehicles are often severely damaged before they are rebuilt and refurbished parts are typically used during reconstruction. In most states, an inspection of the vehicle is required before the vehicle is allowed to return to the road.

Salvage Title

A Salvage Title is issued on a vehicle damaged to the extent that the cost of repairing the vehicle exceeds approximately 75% of its pre-damage value. This damage threshold may vary by state. Some states treat Junk titles the same as Salvage but the majority use this title to indicate that a vehicle is not road worthy and cannot be titled again in that state. The following eleven states also use Salvage titles to identify stolen vehicles - AZ, FL, GA, IL, MD, MN, NJ, NM, NY, OK and OR.

Title Issued

A state issues a title to provide a vehicle owner with proof of ownership. Each title has a unique number. Each title or registration record on a CARFAX report does not necessarily indicate a change in ownership. In Canada, a registration and bill of sale are used as proof of ownership.

Total Loss Vehicle

An insurance or fleet company declares a vehicle a total loss when a claim exceeds approximately 75% of its pre-damage value or if the vehicle is stolen and not recovered. This damage threshold varies by company. These companies typically take possession and obtain the title. Not all total loss vehicles result in a DMV-reported branded

title. This may occur when an insurance company's definition of a total loss is different than the state DMV's definition for a branded title or when the owner of the vehicle is a self-insured company, like a fleet or rental company.

Follow Us:  facebook.com/CARFAX  [@CARFAXinc](https://twitter.com/CARFAXinc)  [About CARFAX](#)

CARFAX DEPENDS ON ITS SOURCES FOR THE ACCURACY AND RELIABILITY OF ITS INFORMATION. THEREFORE, NO RESPONSIBILITY IS ASSUMED BY CARFAX OR ITS AGENTS FOR ERRORS OR OMISSIONS IN THIS REPORT. CARFAX FURTHER EXPRESSLY DISCLAIMS ALL WARRANTIES, EXPRESS OR IMPLIED, INCLUDING ANY IMPLIED WARRANTIES OF MERCHANTABILITY OR FITNESS FOR A PARTICULAR PURPOSE.

© 2023 CARFAX, Inc., part of S&P Global. All rights reserved.
3/23/23 10:19:53 AM (CDT)

